

Contents

1.	Information on This Operating Instruction	1
1.1	Pictographs Used	2
1.2	Exclusion of Liability	2
2.	Safety Instructions	2
3.	Marking / Intended Use	2
3.1	Marking ATEX/ IECEx	3
3.2	Marking EACEx	4
3.3	Scope of Application	5
3.4	Intended Use	5
4.	Specific Conditions of Use ("X" Marking)	5
5.	Thermal Data	6
5.1	Permissible Medium Temperatures According to Temperature Class	6
5.2	Thermal Resistances Depending on the Diameter of Thermowell / Sensor	6
5.3	Permissible Ambient Temperatures	7
5.3.1	For Sensors without Electronic Components (Transmitters) Mounted in the Connection Head	7
5.3.2	For Sensors with Electronic Components (Transmitters) Mounted in the Connection Head	7
5.3.3	For Intrinsically Safe and Not Intrinsically Safe Circuits Mounted into Housings with Flameproof Enclosure (Ex d)	7
5.3.4	For Process Indicators Model PAXd	8
6.	Commissioning	8
6.1	Electrical Connection	8
6.1.1	Electrical Connection Values	8
6.1.2	Grounding / Electrical Bonding	8
6.2	Cable Entries	8
6.3	Securing Connection Heads with Flameproof Enclosure	9
7.	Installation Drawings	10
8.	Declaration of Conformity	12

1. Information on This Operating Instruction



This manual is not a stand-alone document. It applies only in connection with our operating instruction B08-500 for resistance thermometers and thermocouples.



This manual contains important information on the safe operation of the device. Before taking the device into operation, this manual has to be read and understood by qualified personnel.

If you have any problems or questions, please contact your supplier or contact us directly at:



**ARMANO Messtechnik GmbH
Location Beierfeld**

Am Gewerbepark 9 • 08344 Grünhain-Beierfeld
Tel.: +49 3774 58 – 0 • Fax: +49 3774 58 – 545
mail@armano-beierfeld.com

Location Wesel

Manometerstraße 5 • 46487 Wesel-Ginderich
Tel.: +49 2803 9130 – 0 • Fax: +49 2803 1035
mail@armano-wesel.com

Operating Instructions

Resistance Thermometers TPt...X and Thermocouples TTe...X

1.1 Pictographs Used

In this manual, pictographs are used as hazard warnings.

Particular information, instructions and restrictions designed for the prevention of personal or substantial property damage:



WARNING! Is used to warn you against an imminent danger that may result in personal injury or death.

IMPORTANT! Is used to warn you against a possibly hazardous situation that may result in personal, property or environmental damage.

CAUTION! Is used to draw your attention to important recommendations to be observed. Disregarding them may result in property damage.



DANGER! Indicates a potentially hazardous situation, which may result from hot surfaces. Disregarding the safety instructions may result in severe burns.



DANGER OF EXPLOSION! Indicates a potentially hazardous situation, which may result from existing explosive gases and dusts. Disregarding the safety instructions may result in explosions.



The following symbol highlights **actions** you have to conduct or **instructions** that have to be strictly observed.

1.2 Exclusion of Liability

We accept no liability for any damage or malfunction resulting from incorrect installation, inappropriate use of the device or failure to follow the instructions in this manual.

2. Safety Instructions



IMPORTANT! Disregarding these instructions may result in severe explosions.

- Comply with the instructions in this manual.
- Please also note the supplementary safety instructions in our operating instruction B08-500.
- Comply with the information and restrictions of the prevailing type examination certificate.
- Comply with the requirements of the ATEX directive and the prevailing installation regulations for potentially explosive areas.



Qualified personnel:

- The personnel that is charged for the installation, operation and maintenance of the instrument must hold a relevant qualification and must have sufficient knowledge of explosion protection and its rules and regulations.
- The electrical connection shall be carried out by a fully qualified electrician only.



General safety instructions:

The responsibility for classification of zones and determination of possible temperatures that may affect the equipment lies with the plant operator.

3. Marking / Intended Use



Nameplates or other information on the device shall neither be removed nor obliterated, since otherwise any warranty and manufacturer responsibility expires. Equipment with removed or illegible nameplate shall not be used.

Please check, whether the Ex classification is suitable for the case of application.

3.1 Marking ATEX / IECEx

3.1.1 Nameplate

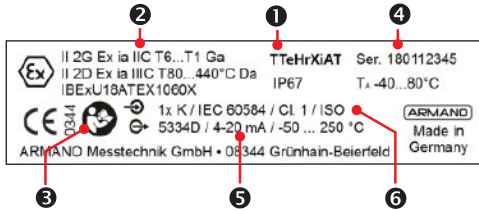

- 1 Model
- 2 Ex marking
- 3 Symbol "Please regard manual"

- 4 Serial number (the first four digits represent the year of manufacture, followed by the week of manufacture)
- 5 Characteristics output signal for transmitters: transmitter model / signal range / temperature range
For instruments without transmitter the annotation "without Transmitter"
- 6 Characteristics input side for thermocouples: number x measuring element / product standard / accuracy class / hot junction (ISO = insulated; GND = hot junction welded to sheath)
Characteristics input side for resistance thermometers: number x measuring element / product standard / accuracy class / connection method (2-, 3- or 4-wire connection: 2W, 3W, 4W)

3.1.2 Ex Markings and Permissible Zones

Models	Marking	Permissible zones	Installation drawing ¹⁾
TPtHrXiA(T) TPtSrXiA(T) TTeHrXiA(T) TTeSrXiA(T)	II 1G Ex ia IIC T6...T1 Ga	0, 1, 2	1
	II 1/2G Ex ia IIC T6...T1 Ga/Gb ³⁾	0 (mounting), 1, 2	2
	II 2G Ex ia IIC T6...T1 Gb	1, 2	1
	II 2G Ex ib IIC T6...T1 Gb	1, 2	1
	II 1D Ex ia IIIC T80 °C...T440 °C Da	20, 21, 22	1
	II 1/2D Ex ia IIIC T80 °C...T440 °C Da/Db ³⁾	20 (mounting), 21, 22	2
TPtHrXdA(T) TPtSrXdA(T) TTeHrXdA(T) TTeSrXdA(T)	II 2D Ex ia IIIC T80 °C...T440 °C Db	21, 22	1
	II 2D Ex ib IIIC T80 °C...T440 °C Db	21, 22	1
	II 1G Ex ia db IIC T6...T1 Ga ²⁾⁴⁾	0, 1, 2	5
	II 1/2G Ex db IIC T6...T1 Ga/Gb ³⁾	0 (mounting), 1, 2	4
	II 1/2G Ex ia/db IIC T6...T1 Ga/Gb ²⁾³⁾⁴⁾	0 (mounting), 1, 2	6
	II 2G Ex db IIC T6...T1 Gb	1, 2	3
TPtMiXiAo(T) TTeMiXiAo(T)	II 1D Ex ia tb IIIC T80 °C...T440 °C Da ²⁾⁴⁾	20, 21, 22	5
	II 1/2D Ex ia/tb IIIC T80 °C...T440 °C Da/Db ²⁾³⁾⁴⁾	20 (mounting), 21, 22	6
	II 2D Ex tb IIIC T80 °C...T440 °C Db	21, 22	3
	II 1G Ex ia IIC T6...T1 Ga ⁵⁾	0, 1, 2	1
	II 2G Ex ia IIC T6...T1 Gb ⁵⁾	1, 2	1
	II 2G Ex ib IIC T6...T1 Gb ⁵⁾	1, 2	1
TPtPAXd(T) TTePAXd(T)	II 1D Ex ia IIIC T80 °C...T440 °C Ga ⁵⁾	20, 21, 22	1
	II 2D Ex ia IIIC T80 °C...T440 °C Gb ⁵⁾	21, 22	1
	II 2D Ex ib IIIC T80 °C...T440 °C Gb ⁵⁾	21, 22	1
	II 1G Ex ia db IIC T6...T1 Ga	0, 1, 2	5
	II 1/2G Ex db IIC T6...T1 Ga/Gb ³⁾	0 (mounting), 1, 2	4
	II 1/2G Ex ia/db IIC T6...T1 Ga/Gb ³⁾	0 (mounting), 1, 2	6
TPtPAXd(T) TTePAXd(T)	II 2G Ex db IIC T6...T1 Gb	1, 2	3
	II 1D Ex ia tb IIIC T80 °C...T440 °C Da	20, 21, 22	5
	II 1/2D Ex ia/tb IIIC T80 °C...T440 °C Da/Db ³⁾	20 (mounting), 21, 22	6
	II 2D Ex tb IIIC T80 °C...T440 °C Db	21, 22	3

¹⁾ ⇒ chapter 7 "Installation Drawings"

²⁾ only with intrinsically safe TPtMiXiAo(T) / TTeMiXiAo(T) – measuring insert

³⁾ only with thermowell suitable for zone separation, applies to devices with neck tube (Hr)

⁴⁾ not with display in the connection head

⁵⁾ only with suitable protective fitting

3.2 Marking EACEx

3.2.1 Nameplate

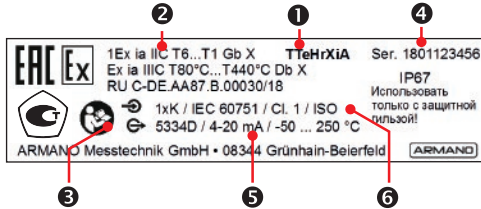

- ❶ Model
- ❷ Ex marking
- ❸ Symbol "Please regard manual"

- ❹ Serial number (the first four digits represent the year of manufacture, followed by the week of manufacture)
- ❺ Characteristics output signal for transmitters: transmitter model / signal range / temperature range
For instruments without transmitter the annotation "without Transmitter"
- ❻ Characteristics input side for thermocouples: number x measuring element / product standard / accuracy class / hot junction (ISO = insulated; GND = hot junction welded to sheath)
Characteristics input side for resistance thermometers: number x measuring element / product standard / accuracy class / connection method (2-, 3- or 4-wire connection: 2W, 3W, 4W)

3.2.2 Ex Markings and Permissible Zones

Models	Marking	Permissible zones	Installation drawing ¹⁾
TPtHrXiA(T) TPtSrXiA(T) TTeHrXiA(T) TTeSrXiA(T)	0Ex ia IIC T6...T1 Ga X	0, 1, 2	1
	Ga/Gb Ex ia IIC T6...T1 X ³⁾	0 (mounting), 1, 2	2
	1Ex ia IIC T6...T1 Gb X	1, 2	1
	1Ex ib IIC T6...T1 Gb X	1, 2	1
	Ex ia IIIC T80 °C...T440 °C Da X	20, 21, 22	1
	Ex ia IIIC T80 °C...T440 °C Da/Db X ³⁾	20 (mounting), 21, 22	2
	Ex ia IIIC T80 °C...T440 °C Db X	21, 22	1
TPtHrXdA(T) TPtSrXdA(T) TTeHrXdA(T) TTeSrXdA(T)	Ex ib IIIC T80 °C...T440 °C Db X	21, 22	1
	0Ex ia db IIC T6...T1 Ga X ²⁾⁴⁾	0, 1, 2	5
	Ga/Gb Ex db IIC T6...T1 X ³⁾	0 (mounting), 1, 2	4
	Ga/Gb Ex ia/db IIC T6...T1 X ²⁾³⁾⁴⁾	0 (mounting), 1, 2	6
	1Ex db IIC T6...T1 Gb X	1, 2	3
	Ex ia tb IIIC T80 °C...T440 °C Da X ²⁾⁴⁾	20, 21, 22	5
	Ex ia/tb IIIC T80 °C...T440 °C Da/Db X ²⁾³⁾⁴⁾	20 (mounting), 21, 22	6
TPtMiXiAo(T) TTeMiXiAo(T)	Ex tb IIIC T80 °C...T440 °C Db X	21, 22	3
	0Ex ia IIC T6...T1 Ga X ⁵⁾	0, 1, 2	1
	1Ex ia IIC T6...T1 Gb X ⁵⁾	1, 2	1
	1Ex ib IIC T6...T1 Gb X ⁵⁾	1, 2	1
	Ex ia IIIC T80 °C...T440 °C Da X ⁵⁾	20, 21, 22	1
	Ex ia IIIC T80 °C...T440 °C Db X ⁵⁾	21, 22	1
	Ex ib IIIC T80 °C...T440 °C Db X ⁵⁾	21, 22	1
TPtPAXd(T) TTePAXd(T)	0Ex ia db IIC T6...T1 Ga X	0, 1, 2	5
	Ga/Gb Ex db IIC T6...T1 X ³⁾	0 (mounting), 1, 2	4
	Ga/Gb Ex ia/db IIC T6...T1 X ³⁾	0 (mounting), 1, 2	6
	1Ex db IIC T6...T1 Gb X	1, 2	3
	Ex ia tb IIIC T80 °C...T440 °C Da X	20, 21, 22	5
	Ex ia/tb IIIC T80 °C...T440 °C Da/Db X ³⁾	20 (mounting), 21, 22	6
	Ex tb IIIC T80 °C...T440 °C Db X	21, 22	3

¹⁾ ⇨ chapter 7 "Installation Drawings"

²⁾ only with intrinsically safe TPtMiXiAo(T) / TTeMiXiAo(T) – measuring insert

³⁾ only with thermowell suitable for zone separation, applies to devices with neck tube (Hr)

⁴⁾ not with display in the connection head

⁵⁾ only with suitable protective fitting

3.3 Scope of Application

The manual is valid for the products listed below. It contains additional information concerning the explosion protection. This manual is applicable in combination with the basic operating instructions for resistance thermometers and thermocouples (⇒ B08-500). Information, which is not given in this manual, can be found in the respective product data sheets if necessary.

Explosion-protected resistance thermometers

Model	Data sheet	Model	Data sheet
TPtHrXiA	8526	TPtSrXdA	8535
TPtSrXiA	8536	TPtMiXiAo	8566
TPtHrXdA	8525	TPtPAXd	8590

Explosion-protected thermocouples

Model	Data sheet	Model	Data sheet
TTeHrXiA	8626	TTeSrXdA	8635
TTeSrXiA	8636	TTeMiXiAo	8666
TTeHrXdA	8625	TTePAXd	8690

3.4 Intended Use

Our resistance thermometers / thermocouples are suitable for the temperature measurement in liquids, gases or at solid bodies in potentially explosive areas. Applications that are not explicitly listed as according to regulations, are improper to intended purpose!

4. Specific Conditions of Use ("X" Marking)

- A higher or lower operating temperature can occur at the measuring tip due to the process; however, the permissible operating temperature at the connection head must not be exceeded. This has to be ensured by the operator under the respective operating conditions by means of a sufficient length of sensor and protective fitting. Referring to this, the length of the neck tube has to be selected so that heating or cooling of the connection head due to the process is negligible.
- Flameproof joints are not intended to be repaired.
- The operator has to ensure that the devices are installed into the thermowells so as to guarantee degree of protection IP67 and to avoid zone entrainment.
- Unused cable entries have to be closed with screw plugs, certified in accordance with the ignition protection type.
- If the wall thickness of the thermowell is between 0.2 mm and 1 mm, the devices must not be subjected to ambient stresses that may have an adverse effect on the partition.
- Electronic components (transmitters, digital displays) mounted in instruments with the ignition protection type Ex i, must hold their own EU type examination certificate. The conditions and intrinsically safe parameters of the respective type examination certificate have to be observed.
- The models TPtMiXiAo(T), TTeMiXiAo(T) shall only be used if they are mounted in a suitable housing.
- From a safety-relevant point of view, for thermocouples with grounded hot junction, the intrinsically safe circuits must be considered galvanically connected to the earth potential, which is why electrical bonding must be secured for the entire installation of the intrinsically safe circuits. In addition, separate conditions in accordance with DIN EN 60079-14 must be observed for the connection.
- In applications that require an EPL Ga or Da, the installation of sensors, which use housing parts made of light metals (e.g. connection heads made of aluminum or thermowells made of titanium), has to be carried out in a way that mechanical impact or friction between the light metal and the steel does not cause sparks (except for stainless steel if the presence of rust particles can be excluded).
- For compliance with the mentioned temperature class / maximum surface temperature at the connection head, the maximum power dissipation P_{max} must not be exceeded. In case of fault, this must be guaranteed by appropriate means (e.g. a fuse connected in series to the loads).
- The permissible medium temperature depends on the maximum permissible input power P_i , the indicated temperature class and the ambient temperature range. The ambient temperature range is defined by the used components. Additional information can be found in the operating instruction.
- For instrument versions with an ambient temperature $> 60\text{ °C}$, heat-resistant screwed cable glands and connection cables (min. 95 °C) have to be used.

Operating Instructions

Resistance Thermometers TPt...X and Thermocouples TTe...X

5. Thermal Data

5.1 Permissible Medium Temperatures According to Temperature Class



Even in the event of a fault, the maximum permissible temperature at the temperature sensor or thermowell must not exceed the ignition point of the potentially explosive medium less a safety factor.

Measuring resistors in particular, but also the wires of a thermocouple can heat considerably in the event of a fault. As a consequence, the temperature sensor or the thermowell heats as well. The operator must ensure that the power in case of error is limited so that the permissible temperature is not exceeded. This also applies to sensors with flameproof enclosure, which are connected to not intrinsically safe circuits, provided that the temperature sensor is located in a potentially explosive area.

For safe operation, the following condition has to be met:

$$T_{\max} \leq P_O \cdot R_{TH} + T_M$$

T_{\max} maximum permissible temperature depending on the temperature class (⇒ table 1)

T_M medium temperature

P_O maximum power of the connected circuit

R_{TH} thermal resistance of the thermowell tip / sensor tip (⇒ table 2)

Temperature class	Ignition point (T_{ig})	Maximum temperature (T_{\max})
T6	85 °C	80 °C
T5	100 °C	95 °C
T4	135 °C	130 °C
T3	200 °C	195 °C
T2	300 °C	290 °C
T1	450 °C	440 °C

Table 1: permissible temperatures at the sensor or thermowell tip (measuring component) according to temperature class

5.2 Thermal Resistances Depending on the Diameter of Thermowell / Sensor

The following thermal resistances are valid for the listed thermowells if these are made of a stainless steel with a thermal conductivity of approximately 15 W/(m·K). Usually, these steel grades are those materials with the lowest thermal conductivity applied in the temperature measuring technology. Examples for these steel grades are 1.4301 (304), 1.4401 (316), 1.4404 (316L) or 1.4571 (316Ti).

When using materials with a better thermal conductivity, you can either take the values from table 2 as a basis or, if this is not sufficient, you can request the corresponding values from the ARMANO Messtechnik GmbH.

Measuring element		Platinum measuring resistor Pt100			Thermocouple		
Sensor diameter		3 mm	6 mm	8 mm ¹⁾	3 mm	6 mm	8 mm ¹⁾
1	without thermowell	128	78	42	15	7.5	5
2	with thermowell 6 x 1 mm	56	–	–	10	–	–
3	with thermowell 9 x 1 mm	–	27	–	–	3	–
4	with thermowell 11 x 2 mm	–	27	–	–	3	–
5	with thermowell 12 x 2.5 mm	–	24	–	–	3	–
6	with thermowell 14 x 2.5 mm	–	–	16	–	–	3
7	tapered measuring tip 6 mm	58	–	–	10	–	–
8	tapered measuring tip 9 mm	–	27	–	–	3	–
9	form 4 acc. to DIN 43772 Ø 18 mm	16	–	–	5	–	–
10	form 4 acc. to DIN 43772 Ø 24 mm	–	16	–	–	1	–
11	form 4 acc. to DIN 43772 Ø 26 mm	–	16	16	–	1	1
12	form 6, 7, 9 DIN 43772 Ø 17 mm	–	16	16	–	1	1

¹⁾ 6 mm measuring insert with 8 mm crimped sleeve

Table 2: thermal resistances in K/W depending on the thermowell / sensor diameter

Operating Instructions

Resistance Thermometers TPt...X and Thermocouples TTe...X

Further possible material groups for thermometer thermowells are:

Material group	Example
non- and low-alloy steel	P250GH, 16Mo3, 13CrMo44
heat- and creep-resistant steel grades	1.4841, 1.4761, 1.4876
pure nickel and nickel-base alloys	Ni201, Inconel 600, Hastelloy C276
other metals and alloys	titanium, tantalum, cobalt-base alloys

Information on the thermal resistances to be applied



The measuring insert inside the thermowell theoretically may heat up according to the values from table 2 row 1. If the operator wants to include the thermowell into his consideration, i.e. applying a lower thermal resistance according to rows 2 – 12 from table 2, it must be ensured that the mounting parts (connection head, screwed cable gland, M24 screw fitting, screw fitting to the thermowell etc.) are technically gas-tight and designed at least with degree of protection IP67 according to DIN EN 60529.



This has to remain unchanged during the ongoing operation, even when using intrinsically safe circuits.

5.3 Permissible Ambient Temperatures

5.3.1 For Sensors without Electronic Components (Transmitters) Mounted in the Connection Head

For sensors without electronic components, the permissible ambient temperature is restricted due to the screwed cable gland. When using other screwed cable glands, it must be ensured that those are sufficiently temperature-resistant. A temperature resistance beyond the range $-40 / +85$ °C cannot be achieved. The screwed cable glands mentioned below are only allowed for operation with intrinsically safe sensors. Sensors with flameproof enclosure are usually supplied without screwed cable glands. These have to be mounted on site.

Applies to TPtHrXiA, TTeHrXiA, TPtSrXiA, TTeSrXiA, TPtMiXiAo, TTeMiXiAo

Temperature class	Ambient temperature ranges		
	Standard screw fitting	Screwed cable gland brass, nickel-plated ¹⁾	Screwed cable gland polyamide ²⁾
T6	$-40 / +80$ °C	$-30 / +80$ °C	$-20 / +80$ °C
$\geq T5$	$-40 / +85$ °C	$-30 / +85$ °C	
T85 °C	$-40 / +80$ °C	$-30 / +80$ °C	
$\geq T100$ °C	$-40 / +85$ °C	$-30 / +85$ °C	

5.3.2 For Sensors with Electronic Components (Transmitters) Mounted in the Connection Head

Applicable for the transmitter models 5331D, 5333D, 5334B, 5337D, 5350B

Applies to TPtHrXiAT, TTeHrXiAT, TPtSrXiAT, TTeSrXiAT, TPtMiXiAoT, TTeMiXiAoT

The following temperature ranges are valid for standard transmitters, which are available at the ARMANO Messtechnik GmbH:

Temperature class	Ambient temperature	Maximum power dissipation
T6	$-40 / +45$ °C	0.84 W
T5	$-40 / +60$ °C	
$\geq T4$	$-40 / +85$ °C	
T85 °C	$-40 / +45$ °C	
T100 °C	$-40 / +60$ °C	
$\geq T135$ °C	$-40 / +85$ °C	

5.3.3 For Intrinsically Safe and Not Intrinsically Safe Circuits Mounted into Housings with Flameproof Enclosure (Ex d)

Applies to TPtHrXdA(T), TTeHrXdA(T), TPtSrXdA(T), TTeSrXdA(T)

Temperature class	Ambient temperature	Maximum power dissipation
T6	$-40 / +60$ °C	1.9 W
$\geq T5$	$-40 / +75$ °C	
T85 °C	$-40 / +60$ °C	
$\geq T100$ °C	$-40 / +75$ °C	

¹⁾ screwed cable gland SKINTOP® MS-M / MSR-M ATEX, company Lapp

²⁾ screwed cable gland SKINTOP® K-M / KR-M ATEX, company Lapp

Operating Instructions

Resistance Thermometers TPt...X and Thermocouples TTe...X

5.3.4 For Process Indicators Model PAXd

5.3.4.1 For Ignition Protection Type "Intrinsic Safety" (Ex ia)

Applies to TPtPAXd, TTePAXd

Temperature class	Ambient temperature	
	Housing aluminum	Housing stainless steel
T6 / T60 °C	-40 / +45 °C	-40 / +45 °C
T5 / T75 °C	-40 / +60 °C	-40 / +60 °C
≥T4 / T100 °C	-40 / +85 °C	-40 / +80 °C

5.3.4.2 For Ignition Protection Type "Flameproof Enclosure" (Ex d) and "Protection by Enclosure" (Ex t)

Applies to TPtPAXd, TTePAXd

Temperature class	Ambient temperature	
	Housing aluminum	Housing stainless steel
Ex d T6	-40 / +70 °C	-40 / +70 °C
T5	-40 / +85 °C	-40 / +80 °C
≥T4	-40 / +85 °C	-40 / +80 °C
Ex t T85 °C	-40 / +70 °C	-40 / +70 °C
T100 °C	-40 / +85 °C	-40 / +80 °C

6. Commissioning

6.1 Electrical Connection

 See also chapter 4.

For the electrical connection of the sensors, transmitters or displays ⇒ B08-500 "Operating Instructions for Resistance Thermometers and Thermocouples".

6.1.1 Electrical Connection Values

For sensors without electronic components, the following values apply:

Equipment group	Temperature class	Maximum power (P)	Maximum voltage (U)
II 1G II 2G	T1...T6	depending on temperature class, process temperature and thermal resistance, but max. 1.9 W	30 V DC
II 1D II 2D	≤ T70 °C	650 mW	
	> T70 °C	550 mW	

For sensors with electronic components mounted in the connection head (transmitters and, if available, digital display), the connection values of the components do apply. For standard ARMANO Messtechnik GmbH head-mount transmitters, the following values do apply:

Transmitter model	5331D, 5333D, 5334B, 5337D	Process indicator PAXd (7501)
Ui		30 V DC
Ii		120 mA
Pi		0.84 W
Li	10 µH	0 µH
Ci	1.0 nF	2.0 nF

6.1.2 Grounding / Electrical Bonding

The connection heads of sensors with flameproof enclosure as well as intrinsically safe sensors when using the heads XE-BUZ, XE-BUZ-H and XE-BEG have, both on the outside and on the inside of the housing, terminals for the connection of the electrical bonding. Use these connections when required by the installation regulations (e.g. for thermocouples with welded hot junction or for the installation into non-metal vessels).

Use the following cable cross-sections as maximum:

Applies to sensors with connection head type XD-AD, XD-AD-W, XD-SD, XD-SD-W, XE-BUZ, XE-BUZ-H, XE-BEG as well as for the housings of the process indicators TPtPAXd and TTePAXd

Position of the connecting terminal	Max. cable cross-section [mm ²]	
	Stranded wire	Solid wire
inside	1.5	2.5
outside	4	6

6.2 Cable Entries

Applies to TPtHrXdA, TTeHrXdA, TPtSrXdA, TTeSrXdA, TPtPAXd, TTePAXd



IMPORTANT! Instruments with ignition protection type Ex d are supplied without screwed cable gland as standard. For safe operation, this has to be professionally mounted by the operator and comply with the ignition protection type. Plastic plugs, used during transport, are not permitted for safe operation and have to be replaced. Depending on the type of screwed cable gland, above-mentioned instruments may attain a degree of protection of IP66 – 68.

Operating Instructions

Resistance Thermometers TPt...X and Thermocouples TTe...X

☞ See also chapter 5.2.

Cable entry openings are designed with a threaded hole M20x1.5 as standard. Other cable entries are labelled accordingly.

The cable entries for sensors with connection head are located beneath the screw-on or hinged lid. For the process display PAXd, the cable entries are located above the display.

Position of the cable entries

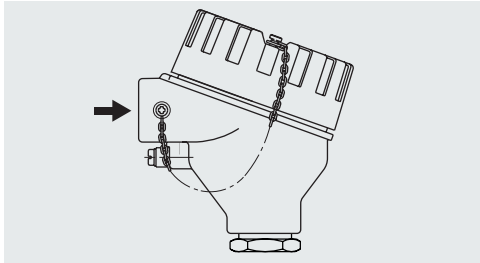

Connection head XD-AD and XD-SD

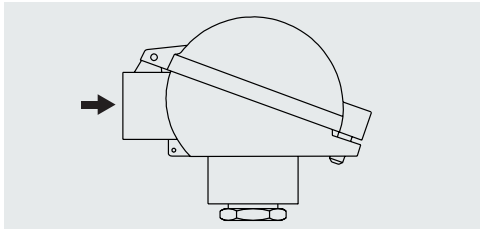

Connection head XE-BUZ and XI-BUZ

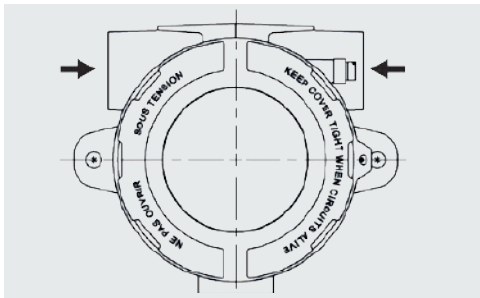

Process display PAXd

6.3 Securing Connection Heads with Flameproof Enclosure

Connection heads with flameproof enclosure must not be opened without tools. Connection heads with screw-on lid are thus equipped with an internal hexagon setscrew for securing the screw-on lid.



IMPORTANT! The locking screw has to be tightened before commissioning.

Locking screw for connection head XD-AD

Applies to TPtHrXdA, TTeHrXdA

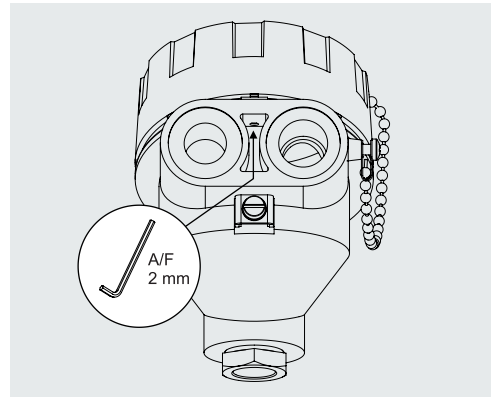

Locking screw for connection head PAXd

Applies to TPtPAXdA, TTePAXdA

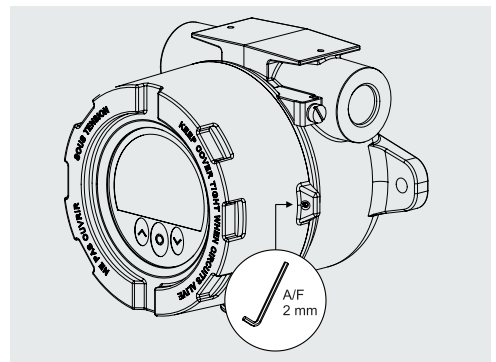

Operating Instructions

Resistance Thermometers TPt...X and Thermocouples TTe...X

7. Installation Drawings

Installation drawing 1

Ex ia Installation

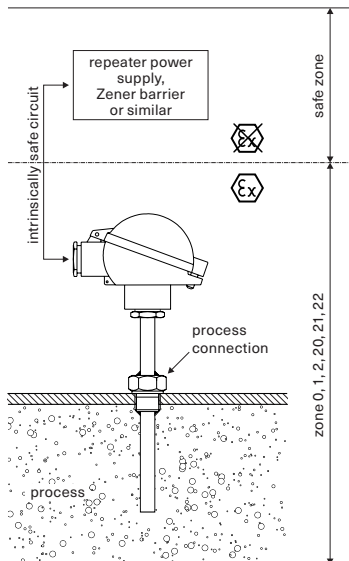

Installation drawing 2

Ex ia Installation (separation of zone 0, 20)

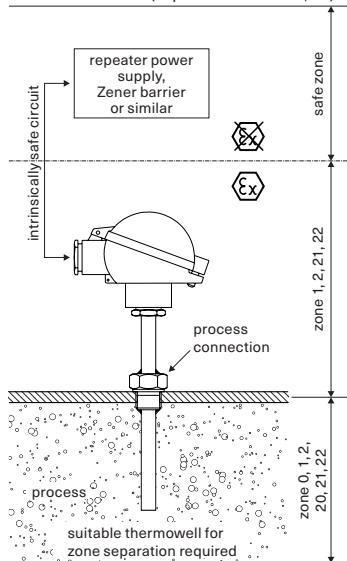

Installation drawing 3

Ex d/tb Installation

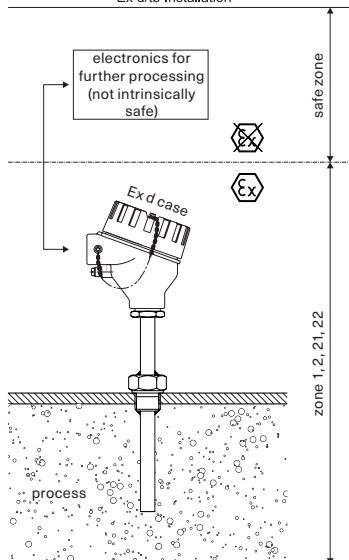

Installation drawing 4

Ex d/tb Installation (separation of zone 0, 21)

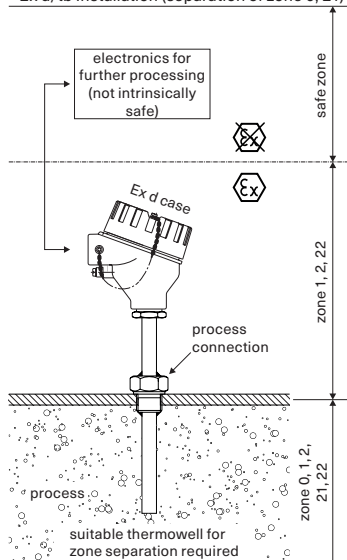

Operating Instructions

Resistance Thermometers TPt...X and Thermocouples TTe...X

Installation drawing 5

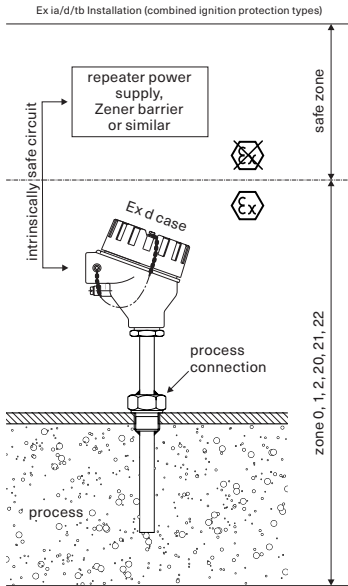

Installation drawing 6

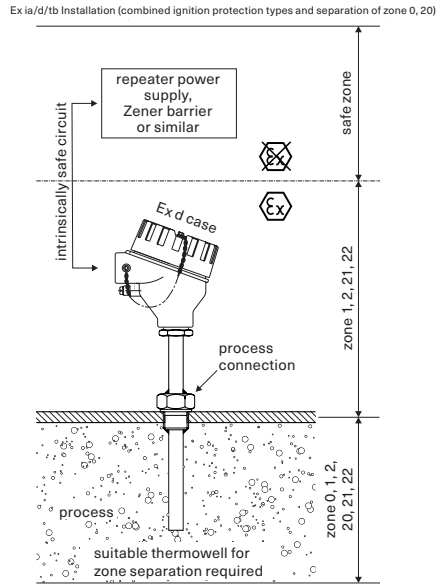

Information on zone separation



If a zone separation shall be provided by the instrument (e.g. process is zone 0 and ambience is zone 1), a thermowell with a minimum wall thickness of 1 mm has to be used. If this is not possible, please refer to chapter 4 "Specific Conditions of Use". The thermowells and process connections have to comply with the requirements of DIN EN 60079-26 and ensure a tightness to degree of protection IP67 according to DIN EN 60529. In this respect, suitable process connections are:

- rigid male thread spigots¹⁾
- turnable union nuts¹⁾
- cutting ring fittings with thread¹⁾
- flanges according to EN 1092, ASME B16.5 or other standards.

¹⁾ Among others, metric male threads, Whitworth threads and NPT pipe threads are suitable as thread types.

Operating Instructions Resistance Thermometers TPt...X and Thermocouples TTe...X

8. Declaration of Conformity

EU-Konformitätserklärung

EU Declaration of Conformity

Für die nachfolgend bezeichneten Erzeugnisse

We hereby declare for the following named goods

WIDERSTANDSTHERMOMETER

Typen TPT...
(Datenblätter 8525, 8526, 8535, 8536, 8566, 8590)

RESISTANCE THERMOMETERS

Models TP...
(data sheets 8525, 8526, 8535, 8536, 8566, 8590)

THERMOELEMENTE

Typen TTe...
(Datenblätter 8625, 8626, 8635, 8636, 8666, 8690)

THERMOCOUPLES

Models TTe...
(data sheets 8625, 8626, 8635, 8636, 8666, 8690)

wird hiermit erklärt, dass sie den wesentlichen Schutzanforderungen entsprechen, die in nachfolgend bezeichneten Richtlinien festgelegt sind:

that they meet the essential protective requirements, which have been fixed in the following directives:

RICHTLINIE 2014/34/EU DES EUROPÄISCHEN PARLAMENTES UND DES RATES vom 26. Februar 2014

DIRECTIVE 2014/34/EU OF THE EUROPEAN PARLIAMENT AND THE COUNCIL from February 26, 2014

zur Harmonisierung der Rechtsvorschriften der Mitgliedstaaten für Geräte und Schutzsysteme zur bestimmungsgemäßen Verwendung in explosionsgefährdeten Bereichen – kurz: **ATEX-Richtlinie**

on the approximation of the laws of the Member States relating to equipment and protective systems intended for use in potentially explosive atmospheres – short: **ATEX Directive**



Zur Beurteilung der Erzeugnisse hinsichtlich der Richtlinien wurden folgende Normen herangezogen:

The following standards have been used to assess the goods regarding the directives:

DIN EN 60079-0:2019-09
DIN EN 60079-1:2015-04
DIN EN 60079-11:2012-06
DIN EN 60079-26:2015-05
DIN EN 60079-31:2014-12

Kennzeichnung:

Marking:

 	TPTHXIA(T), TPTSXIA(T), TTeHXIA(T), TTeSXIA(T): II 1G Ex ia IIC T6...T1 Ga II 1/2G Ex ia IIC T6...T1 Ga/Gb II 2G Ex ia IIC T6...T1 Gb II 2G Ex ib IIC T6...T1 Gb II 1D Ex ia IIIC T80 °C...T440 °C Da II 1/2D Ex ia IIIC T80 °C...T440 °C Da/Db II 2D Ex ia IIIC T80 °C...T440 °C Db II 2D Ex ib IIIC T80 °C...T440 °C Db	TPTHXdA(T), TPTSXdA(T), TTeHXdA(T), TTeSXdA(T), TPTFXdA(T), TTeFXdA(T): II 1G Ex ia db IIC T6...T1 Ga II 1/2G Ex db IIC T6...T1 Ga/Gb II 1/2G Ex ia/db IIC T6...T1 Ga/Gb II 2G Ex db IIC T6...T1 Gb II 1D Ex ia tb IIIC T80 °C...T440 °C Da II 2D Ex tb IIIC T80 °C...T440 °C Db II 1/2D Ex ia/tb IIIC T80 °C...T440 °C Da/Db	TPTMIXIAo(T), TTeMIXIAo(T): II 1G Ex ia IIC T6...T1 Ga II 2G Ex ia IIC T6...T1 Gb II 2D Ex ia IIC T6...T1 Gb II 1D Ex ia IIIC T80 °C...T440 °C Da II 2D Ex ia IIIC T80 °C...T440 °C Db II 2D Ex ib IIIC T80 °C...T440 °C Db
--	---	--	---

Benannte Stelle für die Baumusterprüfbescheinigung:
IBExU Institut für Sicherheitstechnik GmbH
Fuchsmühlenweg 7
09599 Freiberg, DEUTSCHLAND
Kennnummer: **0637**

Notified body for the type examination:
IBExU Institut für Sicherheitstechnik GmbH
Fuchsmühlenweg 7
09599 Freiberg, GERMANY
Identification number: **0637**

Baumusterprüfbescheinigungen:

Type Examination Certificates:

IBExU 18 ATEX 1060 X
IECEX IBE 18.0006X

Überwachung Qualitätsmanagement:
Kennnummer: **0344**

Quality management assessment:
Identification number: **0344**

Diese Erklärung wird verantwortlich für den Hersteller:
This declaration is issued under the sole responsibility of the manufacturer:

ARMANO Messtechnik GmbH
abgegeben durch / by
Grünhain-Beierfeld, 2023-09-26



Bernd Vetter
Geschäftsführender Gesellschafter / Managing Director

ARMANO

ARMANO Messtechnik GmbH

Standort Beierfeld
Am Gewerbestrang 9
08344 Grünhain-Beierfeld
Tel.: +49 3774 58 - 0
Fax: +49 3774 58 - 545
mail@armano-beierfeld.com

Standort Wesel
Manometerstraße 5
46487 Wesel-Ginderich
Tel.: +49 2803 9130 - 0
Fax: +49 2803 1035
mail@armano-wesel.com

www.armano-messtechnik.de

122 EU-Konformitätserklärung/ATEX_TPT... Ausg.09/23